

FELIX
GLUER  | Single



STOP HAND GLUING
go automated!

TECHNICAL DATA:

- The **one-sided** compact gluing plotter
- **Hot melt & cold glue** simultaneous application
- 2 independent up & down stacking work tables, with safety sensors
- Semi-automatic material loading
- Max single table load – 300 kg
- Material stack height – 500 mm
- Camera for remote technical support & service
- PC on Windows with the internet connection
- **FELIX GLUER : Pro** software full license

GLUE ANY MATERIAL:



felt



corrugated cardboard

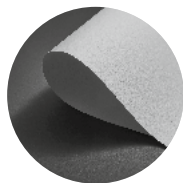

paper



EPS · XPS
Styrofoam



cardboard

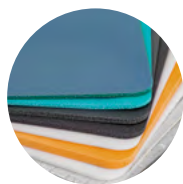

PP foam · PE foam
EVA foam

ANY GLUING PATH POSSIBLE:



line



multiline



dashed line



micro dots



dots



spray

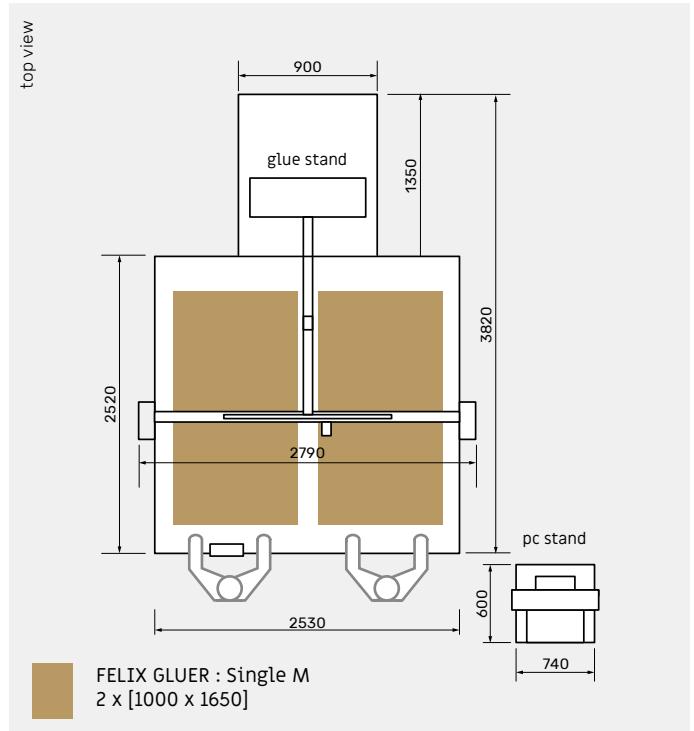

dimensions in mm

FELIX GLUER : Single		
S	[1650 x 1250]	2 x [825 x 1250]
M	[2000 x 1650]	2 x [1000 x 1650]
L	[2200 x 1800]	2 x [1100 x 1800]
XL	[2500 x 1800]	2 x [1250 x 1800]



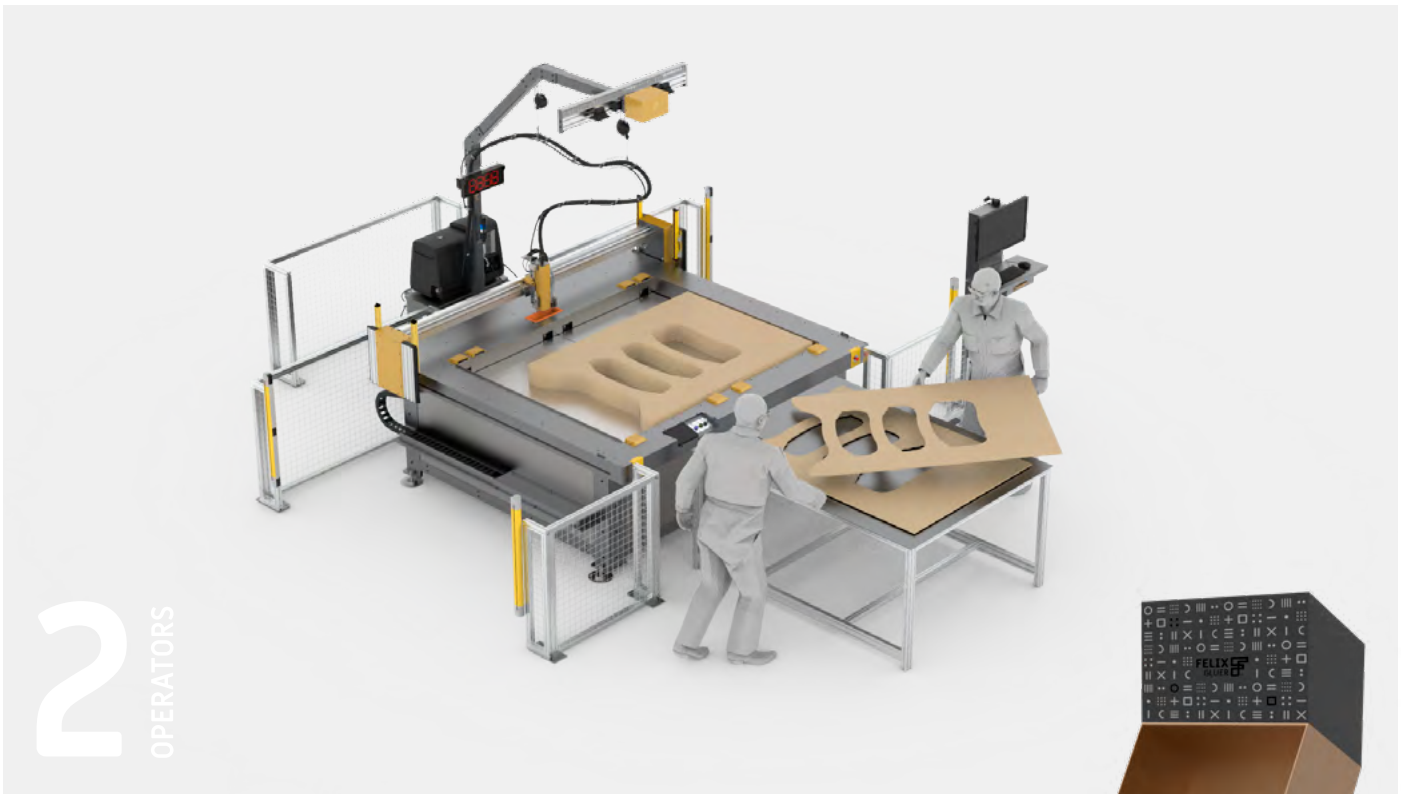
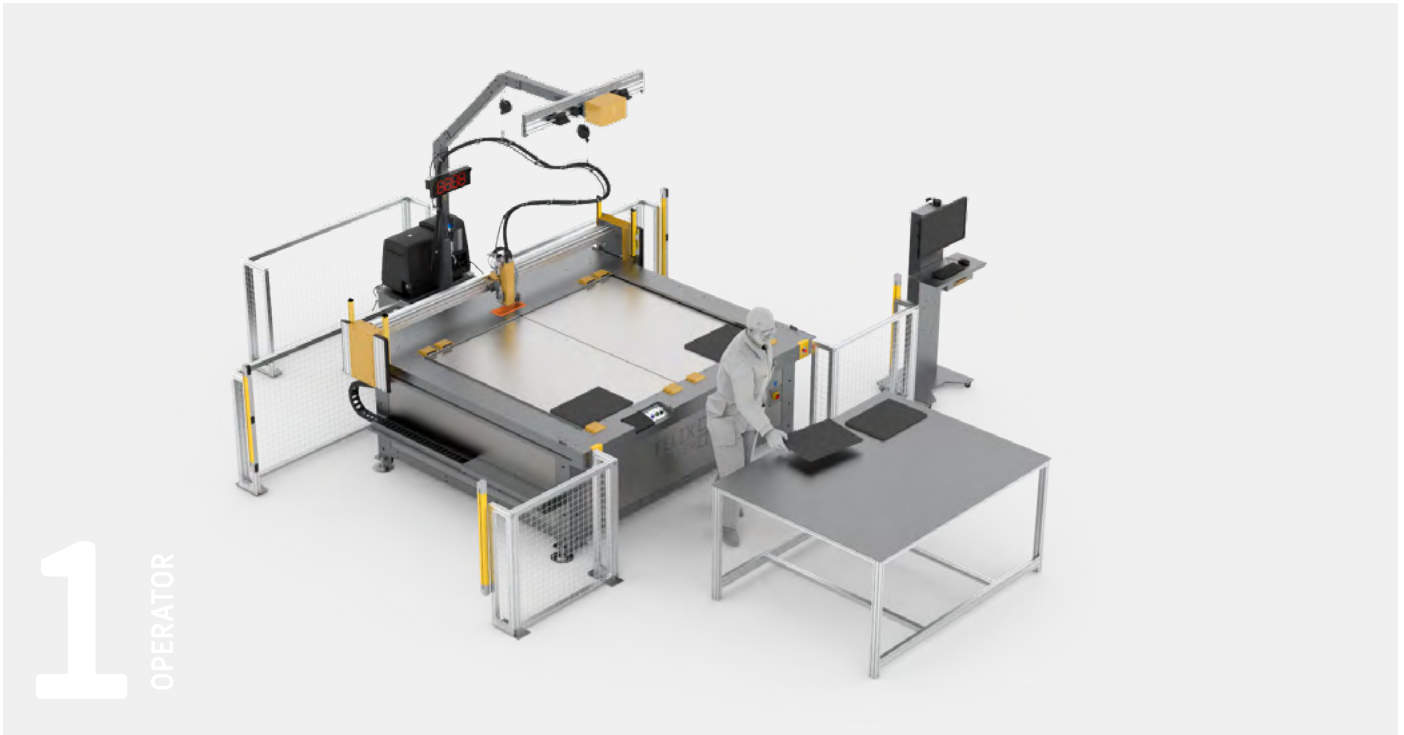

RE:CALCULATE your production, capabilities and costs

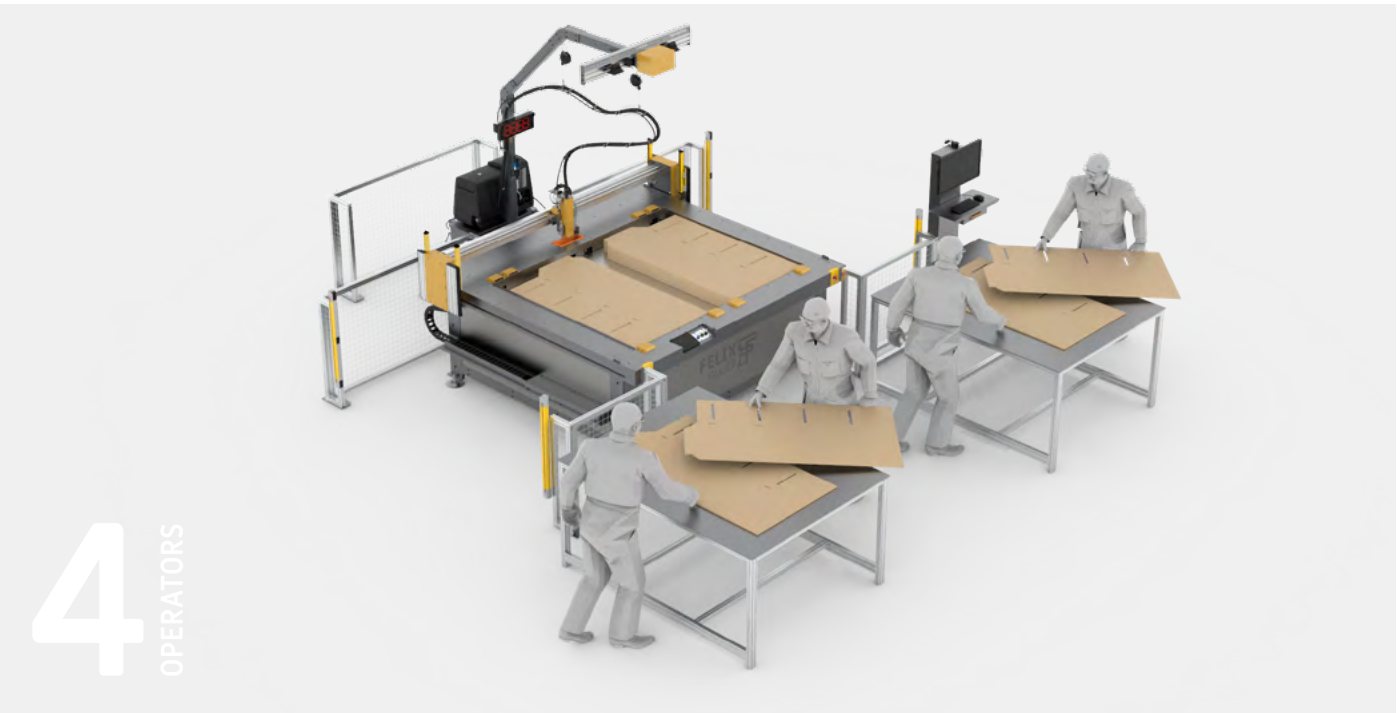
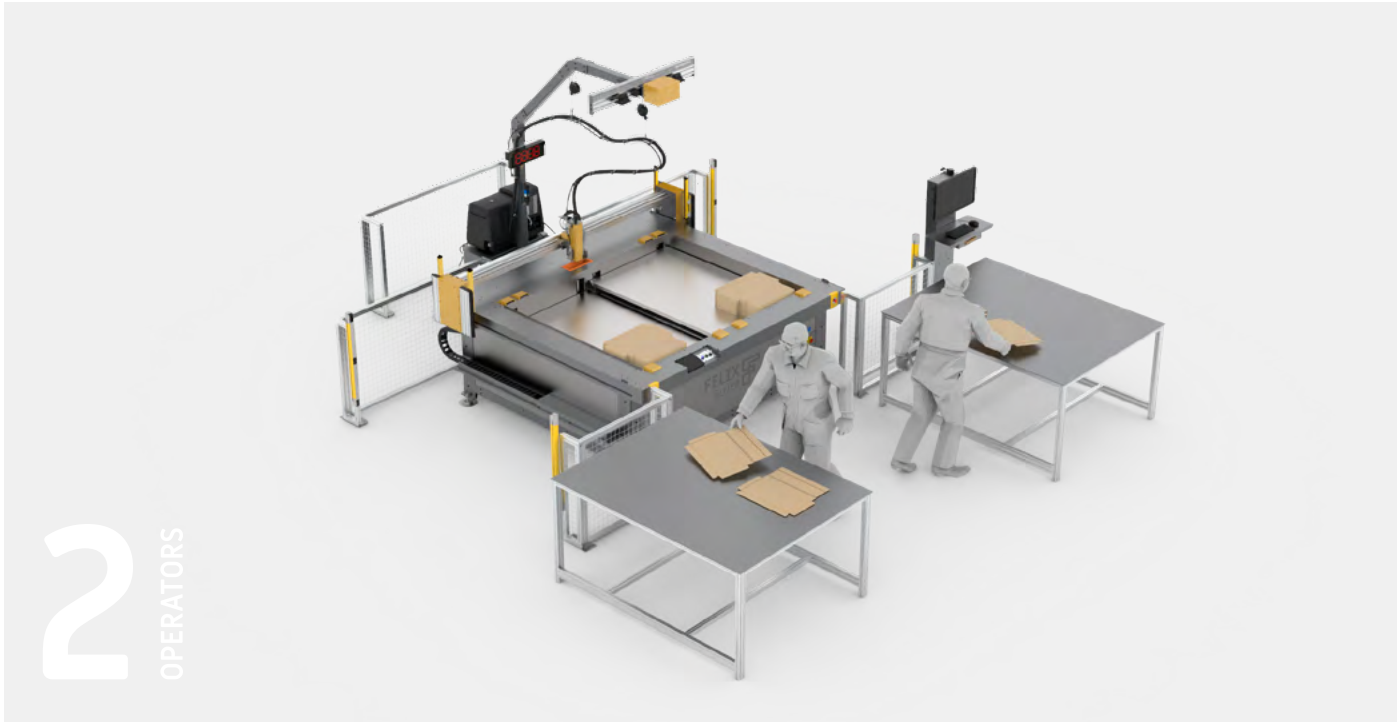
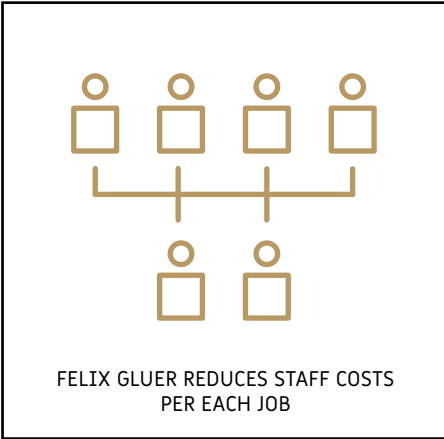
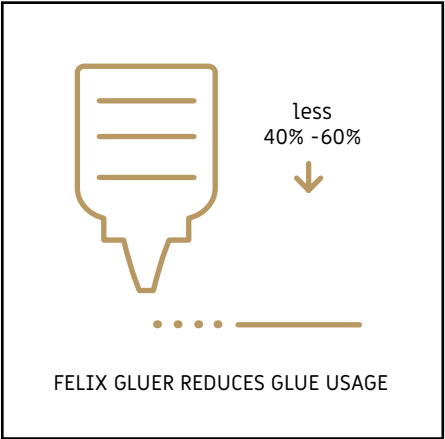
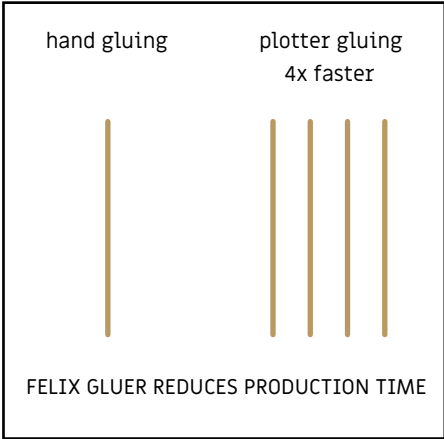

Extend the **FG : Single** configuration to increase productivity.

FELIX GLUER : Photopath system

Easy glue paths design in just 3 steps:

1. The system takes a photo of the implemented/loaded elements.
2. The operator draws glue paths on the photo.
3. The machine applies glue according to the design.

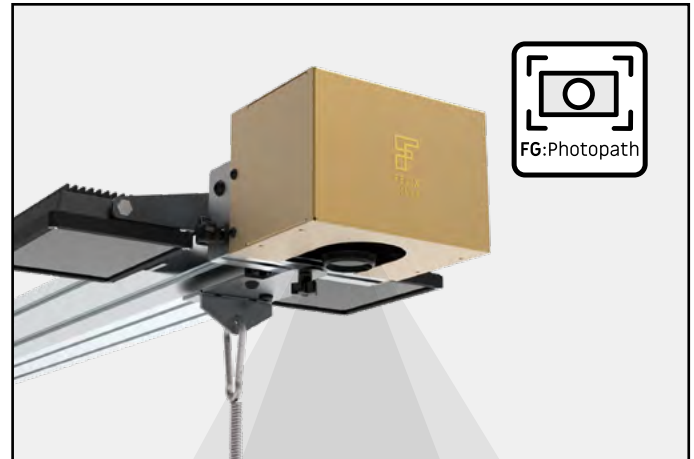

FELIX GLUER : PRO Office

Prepare gluing projects in your office/DTP department & send ready files directly to the machine.

CAD files import:



FELIX GLUER : Card access

Touchless logging system to the FELIX GLUER. Different access levels and roles for machine users: operator/admin/service.

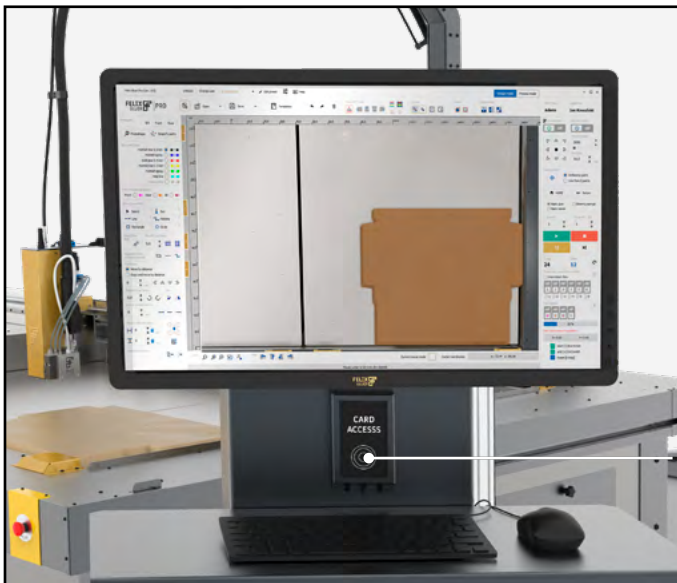

FELIX GLUER : Statistics

Production costs data analyzer.

Calculate:

- gluing time per element or the whole job
- glue consumption per element or the whole job
- production time
- glue weighing option in the machine

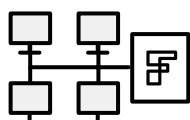

Connect FELIX GLUER to your company's internal network system.

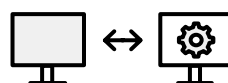

Get remote technical assistance on software and machine operation anytime your operator needs it.

FELIX GLUER : WORLDWIDE INSTALLATIONS & PARTNERS



CONTACT DETAILS



www.felix-gluer.com

Made in EU



list of authorised partners

Office & production:

FELIX LAB sp. z o.o.
ul. Sikorskiego 119
05-080 Klądyn, Poland

Contact for media:

JULIA GRZESIAK
Head of Marketing & PR
julia.grzesiak@felix-gluer.com
+48 780 143 473

International distribution channel:

SŁAWOMIR MARĆ
Sales Channel Manager
+48 501 471 089
slawomir.marc@felix-gluer.com

Service & Technical support:

support@felix-gluer.com